



Construction

Vertical multi-stage close coupled pumps in **chrome-nickel stainless steel, with motor shields in brass.**

Suction connection on the lower casing and delivery connection on the top casing. Motor cooled by the pumped water passing between the motor jacket and the external jacket.

Double mechanical shaft seal with interposed oil chamber.

Applications

For clean water without abrasives or additives aggressive for the materials of the pump.

For domestic, civil and industrial applications.

For installation in confined space with minimum ventilation.

For installation in locations subject to risk of temporary flooding.

For installation in areas exposed to water jetting.

When low-noise operation is required.

Operating conditions

Water temperature up to 35 °C.

Maximum permissible pressure in the pump casing: 10 bar.

Continuous duty.

Motor

2-pole induction motor, 50 Hz (n = 2900 rpm).

MXSU : three-phase 230 V ± 10%;
three-phase 400 V ± 10%.

MXSUM : single-phase 230 V ± 10% , with thermal protector.

Control box with capacitor, on request.

Cable: H07RN-F, 4 x 1 mm², length 2 m.

Insulation class F.

Protection IP 68 (for continuous immersion).

Triple impregnation humidity-proof dry winding.

Constructed in accordance with EN 60335-2-41.

Special features on request

- Other voltages.

- Frequency 60 Hz (as per 60 Hz data sheet).

Materials

Component	Material
External jacket	Chrome-nickel steel 1.4301 EN 10088 (AISI 304)
Suction casing	
Stage casing	
Impeller	
Oil chamber cover	
Spacer sleeve	
Motor jacket	
Shaft	Chrome-nickel steel 1.4305 EN 10088 (AISI 303)
Motor shield	Brass P- Cu Zn 40 Pb 2 UNI 5705
Elbow	
Upper mechanical seal	Steatite, carbon, NBR Ceramic alumina, carbon, NBR
Lower mechanical seal	
Seal lubrication oil	Oil for food machinery and pharmaceutic use

Coverage chart $n \approx 2900$ rpm

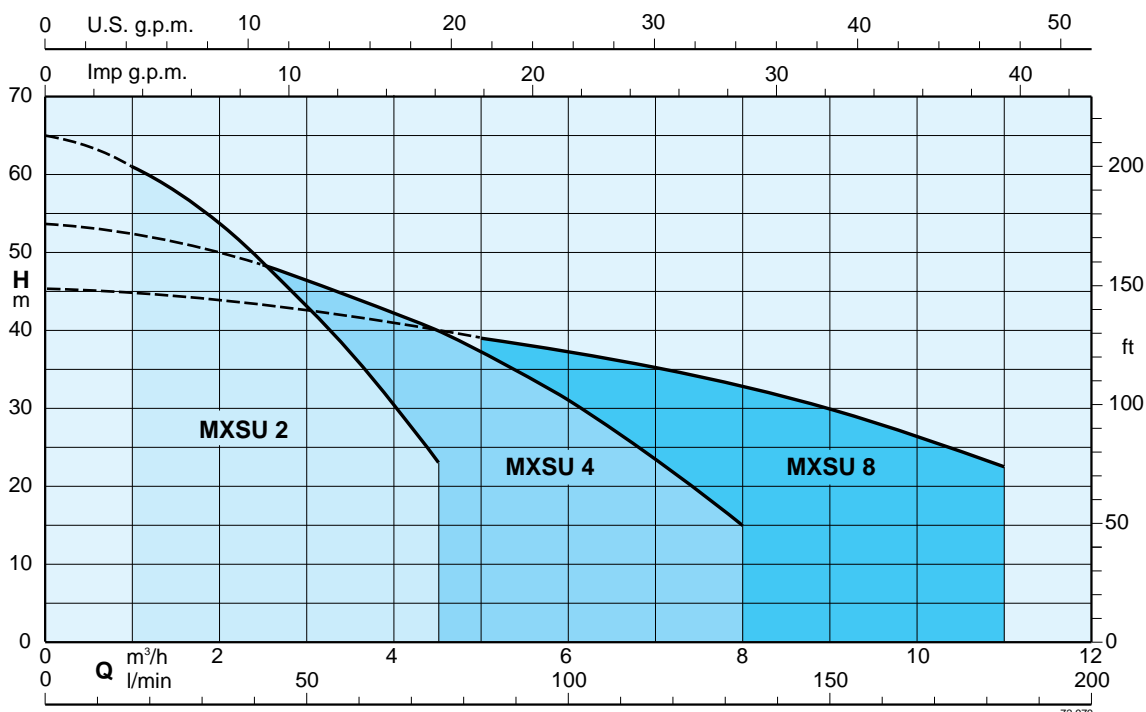

Performance $n \approx 2900$ rpm

	3 ~ 230 V 400 V		1 ~ 230 V	Capacitor			P1		P2		Q	H m								
	A	A		A	μ F	V	kW	kW	HP	0		1	1,5	2	2,5	3	3,5	4	4,5	
MXSU 203	2,4	1,4	MXSUM 203	3,5	20	450	0,8	0,55	0,75	H m	33	31	29,5	27,5	25	22	19	16	12	
MXSU 204	2,7	1,6	MXSUM 204	4,1	20	450	0,95	0,55	0,75		44	41,5	39,5	36,5	33,5	29,5	25,5	21	16	
MXSU 205	3,3	1,9	MXSUM 205	5	20	450	1,1	0,75	1		53	49,5	47	44	40	35	30	25	19	
MXSU 206	3,8	2,2	MXSUM 206	6	25	450	1,3	0,9	1,2		65	61	58	54	49	43	37	30,5	23	

	3 ~ 230 V 400 V		1 ~ 230 V	Capacitor			P1		P2		Q	H m								
	A	A		A	μ F	V	kW	kW	HP	0		2,5	3	3,5	4	4,5	5	6	7	8
MXSU 404	3,8	2,2	MXSUM 404	6	25	450	1,3	0,9	1,2	H m	43	39	38	36,5	34,5	33	30,5	25,5	19,5	13
MXSU 405	4,5	2,6	MXSUM 405	7	25	450	1,55	1,1	1,5		53	48	46,5	45	42,5	40	37,5	31	24	15

	3 ~ 230 V 400 V		1 ~ 230 V	Capacitor			P1		P2		Q	H m							
	A	A		A	μ F	V	kW	kW	HP	0		5	6	7	8	9	10	11	
MXSU 803	4,5	2,6	MXSUM 803	7	25	450	1,55	1,1	1,5	H m	34,5	29,5	28	26,5	24,5	22,5	20	16,5	
MXSU 804	6,6	3,8						1,5	2		45,5	39	37	35	32,5	30	26,5	22,5	

P1 Max. power input.

Tolerances according to ISO 9906, annex A.

P2 Rated motor power output.

Test results with clean cold water, without gas content.

Dimensions and weights

Pump	H mm	kg
MXSU 203	524	11,3
MXSU 204	524	11,5
MXSU 205	548	12
MXSU 206	572	13,3
MXSU 404	524	12,4
MXSU 405	548	12,9
MXSU 803	548	12,5
MXSU 804	548	14,7

Pump	H mm	kg
MXSUM 203	524	12,3
MXSUM 204	524	12,5
MXSUM 205	548	13,6
MXSUM 206	572	14,8
MXSUM 404	524	14
MXSUM 405	548	14,4
MXSUM 803	548	14,1

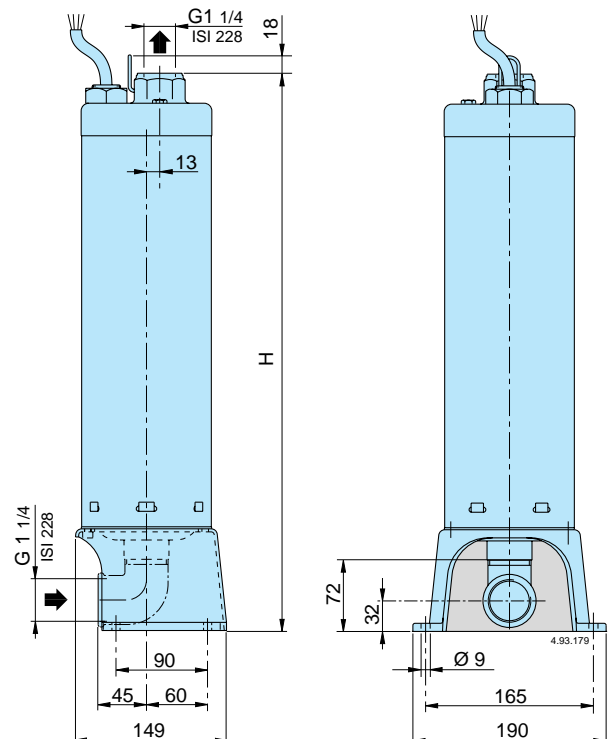

Characteristic curves $n \approx 2900$ rpm

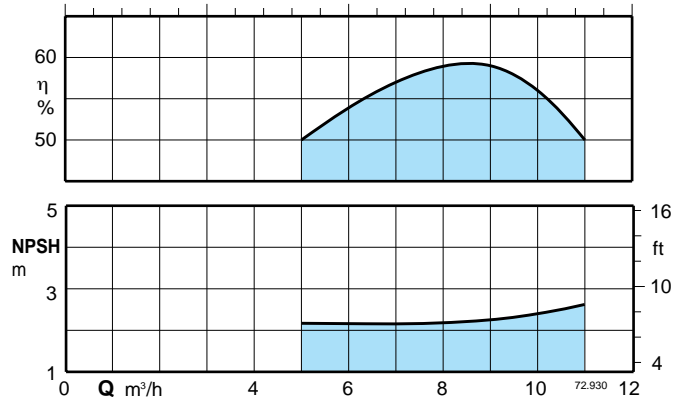
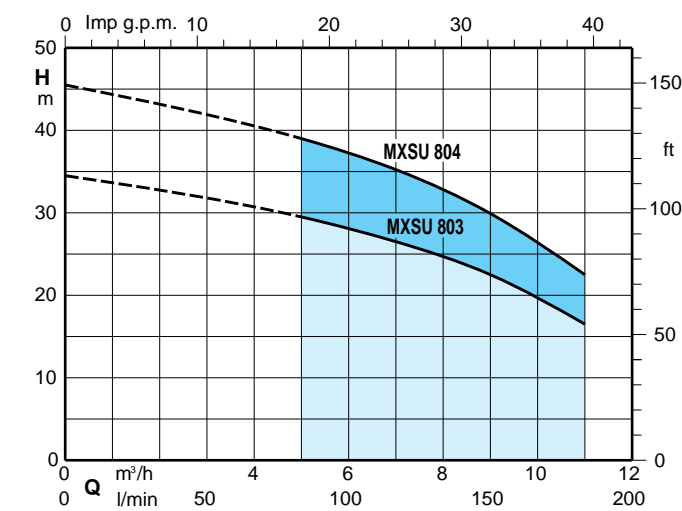
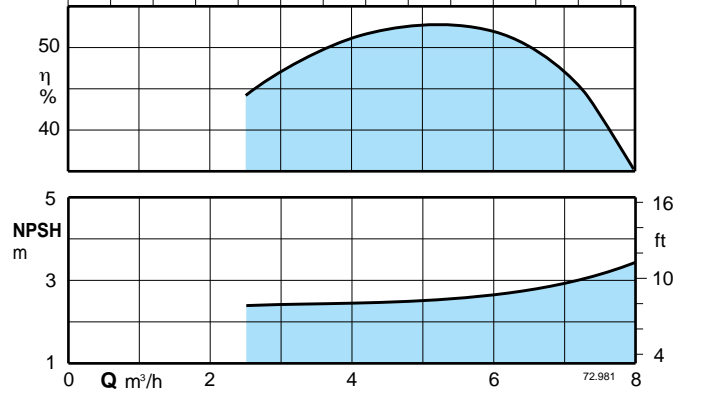
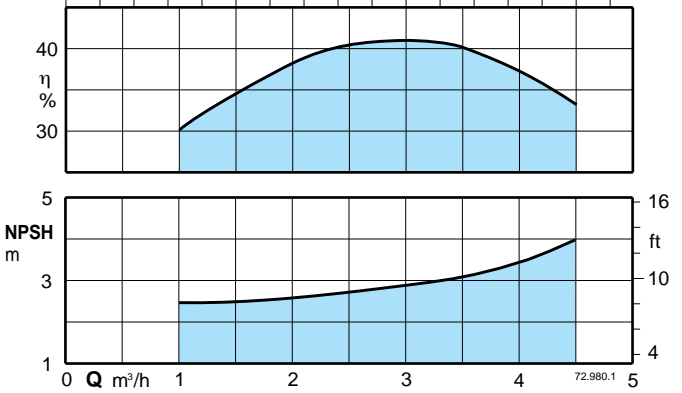
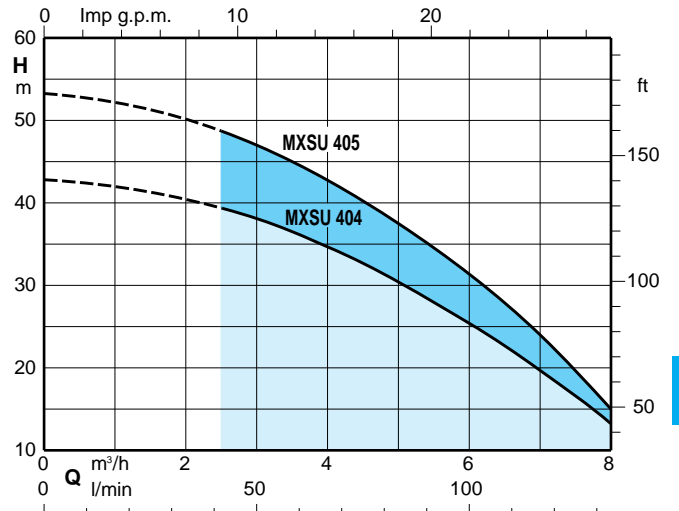
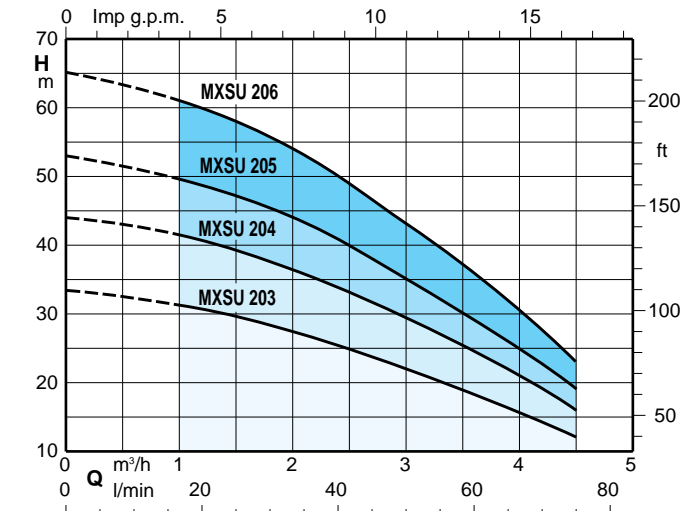

Features

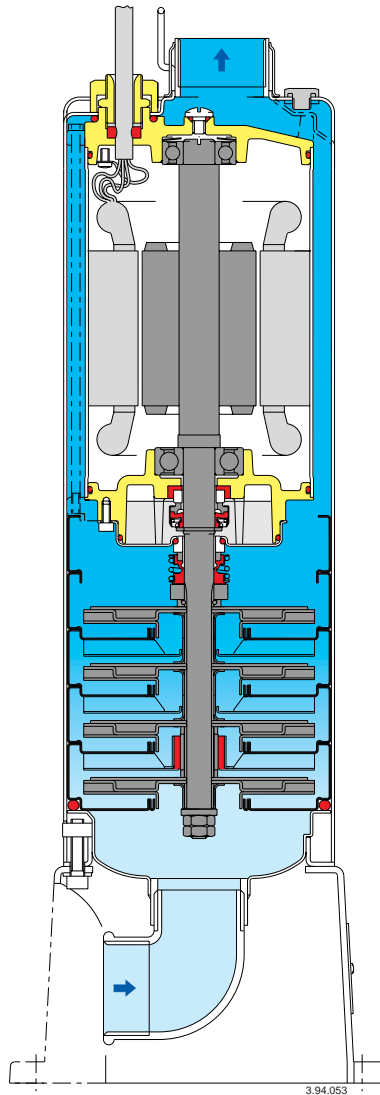

Control box for single-phase pumps (on request)

Pump	Control box	Capacitor	
MXSUM 203	QM 11	20 μ F	450 V
MXSUM 204			
MXSUM 205			
MXSUM 206	QM 12	25 μ F	450 V
MXSUM 404			
MXSUM 405			
MXSUM 803			

