

FDL - FXDL FBDL SERIES

SUBMERSIBLE PUMPS FOR WITH ENTRAINED SOLIDS WASTE WATER

Sewage pumps with power up to 22 kW (30 HP).
Available in **cast iron (FDL)**, **AISI 316 stainless steel (FXDL)**, **B10 bronze (FBDL)**.

FDLV and FXDLV versions with vortex impeller are also available.

APPLICATIONS

- Handling of sewage, liquids, waste water and industrial sludge.
- Draining of flooded excavations and marshy ground.
- Pumping of aggressive liquids (FXDL version) in the chemical industry.
- Pumping of salt water (FBDL version).
- Water display, fountains.

SPECIFICATIONS

- **Maximum liquid temperature: 25-40°C** (see hydraulic performance table)
- **Maximum immersion depth: 20 m.**
- **Passes solids 6 to 100 mm** in diameter (see hydraulic performance table)
- Double seal system, silicon carbide/silicon carbide inner seal, ceramic/carbon or O-ring upper seal, with oil chamber in between.
- Adjustable bottom cover to compensate for impeller wear and ensure stable hydraulic performances.
- **Dry motor** (class F insulation).
- 2-, 4-, 6-pole versions.
- Large-sized motor bearings.
- Power cord: 10 m, H07RN-F type.
- Moisture measuring probe in oil chamber and stator thermal protection probe on most models (see electrical data table).
- FXDL models are equipped with a threaded stainless steel cable gland for the installation of a power cord protection tube.

ACCESSORIES

- Lowering device.
- Delivery coupling.
- Tripod base
- Ball check valve
- Float for laden water
- Command and control boxes.



FDL



FXDL

FBDL

TABLE OF MATERIALS

FDL (V)

PART	MATERIAL
Impeller, Pump body, Motor casing, Casing wear plate, Upper cover	FDL (V)
	250 CAST IRON
Shaft	STAINLESS STEEL (AISI 430)
Bearings	PERMANENTLY LUBRICATED BALL TYPE
Upper mechanical seal	CARBON/CERAMIC O-RING
Inner mechanical seal	SILICON CARBIDE/SILICON CARBIDE
Gaskets	FPM
Nuts and bolts	STAINLESS STEEL (AISI 304)

FXDL (V) - FBDL

PART	MATERIAL	
	FXDL (V)	FBDL
Impeller, Pump body, Motor casing, Volute bottom, Upper cover	STAINLESS STEEL (AISI 316)	B10 STEEL BRONZE
Shaft	STAINLESS STEEL (AISI 630)	
Bearings	PERMANENTLY LUBRICATED BALL TYPE	
Upper mechanical seal	CARBON/CERAMIC OR O-RING	
Inner mechanical seal	SILICON CARBIDE/SILICON CARBIDE	
Gaskets	NITRILE RUBBER	
Nuts and bolts	STAINLESS STEEL (AISI 316)	

FDL-FDLV SERIES ELECTRICAL DATA, 50 Hz

PUMP TYPE	INPUT POWER	rpm	RATED CURRENT In Amp.			PEAK CURRENT Isp (A)		POWER CORD TYPE	STATOR THERMAL PROTECTION**	MOISTURE DETECTION PROBE IN GIL CHAMBER**
			220-240 V Δ	380-415 V Y Δ		220-240 V	380-415 V			
THREEPHASE	kW									
FDL 61-42	1,7	1450	5,4	3,1	-	24		4 x 1,5	NOT	NOT
FDL 62-41	2,6	1450	8,2	4,7	-	36	21	4 x 2,5	NOT	NOT
FDL 64-22	3,5	2850	10	5,8		65	38	4 x 2,5	NOT	NOT
FDL 65-22	5,2	2850	15,3	8,8		78	45	7 x 2,5	YES	YES
FDL 66-21	6,6	2850	19,4	11,2		99	57	7 x 2,5	YES	YES
FDL 81-41	2	1450	6	3,5		27	16	4 x 2,5	NOT	NOT
FDL 82-41	2,8	1450	8,7	5		39	22	4 x 2,5	NOT	NOT
FDL 102-61	3	950	10,5	6		47	27	7 x 2,5	YES	YES
FDL 104-42	4,3	1450	14	8,10		59	34	4 x 2,5	NOT	NOT
FDL 106-41	5,7	1450			10,4		57	12 x 2,5	YES	YES
FDL 107-41	5,9	1450			10		55	12 x 2,5	YES	YES
FDL 107-42	6,5	1450			11,5		63	12 x 2,5	YES	YES
FDL 109-42	9,6	1450			18,5		142	10 x 4	YES	YES
FDL 109-41	11,2	1450			21,5		165	10 x 4	YES	YES
FDL 152-41	15,5	1450			28,5		220	12 x 2,5	YES	YES
FDL 153-43	23,5	1450			41,5		270	10 x 4	YES	YES
FDL 153-42	30,6	1450			54		351	10 x 4	YES	YES

PUMP TYPE	INPUT POWER	rpm	RATED CURRENT In Amp. 220-240 V	CAPACITOR		PEAK CURRENT Isp (A)	POWER CORD TYPE	STATOR THERMAL PROTECTION**	MOISTURE DETECTION PROBE IN OIL CHAMBER
				μF	V				
SINGLE-PHASE	kW								
FDLM 81-41	1,7	1450	8,1	31,5	450	34	4 x 2,5	NOT	NOT

PUMP TYPE	INPUT POWER	rpm	RATED CURRENT In Amp.			PEAK CURRENT Isp (A)		POWER CORD TYPE	STATOR THERMAL PROTECTION**	MOISTURE DETECTION PROBE IN OIL CHAMBER**
			220-240 V Δ	380-415 V Y Δ		220-240 V	380-415 V			
THREE-PHASE	kW									
FDLV 61-42	1,5	1450	4,8	2,8		22	13	4 x 2,5	NOT	NOT
FDLV 61-41	1,6	1450	5	2,9		23	13	4 x 2,5	NOT	NOT
FDLV 62-41	2,5	1450	8	4,6		35	21	4 x 2,5	NOT	NOT
FDLV 81-43	1,5	1450	4,9	2,8		22	13	4 x 2,5	NOT	NOT
FDLV 81-42	1,6	1450	5,2	3		24	14	4 x 2,5	NOT	NOT
FDLV 81-41	1,9	1450	5,8	3,3		27	15	4 x 2,5	NOT	NOT
FDLV 82-42	2,4	1450	7,7	4,4		34	20	4 x 2,5	NOT	NOT
FDLV 82-41	2,8	1450	8,7	5		39	22	4 x 2,5	NOT	NOT
FDLV 83-41	3,2	1450	9,5	5,5		42	25	4 x 2,5	NOT	NOT
FDLV 84-22	4,5	2850	13,6	7,9		70	41	7 x 2,5	YES	YES
FDLV 85-21	6	2850	17,3	10		89	51	7 x 2,5	YES	YES
FDLV 104-41	4,3	1450	14,2	8,2		59	35	4 x 2,5	YES	YES
FDLV 106-42	5,4	1450			9,5		53	12 x 2,5	YES	YES
FDLV 106-41	6,8	1450			12		66	12 x 2,5	YES	YES
FDLV 152-42	24,7	1450			45		293	10 x 4	YES	YES
FDLV 153-41	29,5	1450			53,4		348	10 x 4	YES	YES

PUMP TYPE	INPUT POWER	rpm	RATED CURRENT In Amp. 220-240 V	CAPACITOR		PEAK CURRENT Isp (A)	POWER CORD TYPE	STATOR THERMAL PROTECTION**	MOISTURE DETECTION PROBE IN OIL CHAMBER**
				μF	V				
SINGLE-PHASE	kW								
FDLVM 81-43	1,6	1450	8	31,5	450	34	4 x 2,5	NOT	NOT

FXDL-FBDL SERIES ELECTRICAL DATA, 50 Hz

PUMP TYPE	INPUT POWER	rpm	RATED CURRENT In Amp.		PEAK CURRENT Isp (A)		POWER CORD TYPE	STATOR THERMAL PROTECTION**	MOISTURE DETECTION PROBE IN OIL CHAMBER
			220-240 V Δ	380-415 V Y	220-240 V	380-415 V			
TRIPHASEE	kW								
FXDLV 41-21	0,8	2850	2,8	1,6	13	7	4 x 1,5	NOT	NOT
FXDL 41-21	1	2850	3,3	1,9	15	9	4 x 1,5	NOT	NOT
FXDL 53-22	3,2	2850	9,5	5,5	62	36	4 x 2,5	NOT	NOT
FXDL 62-22	1,7	2850	5	2,9	26	15	4 x 2,5	NOT	NOT
FXDL 62-21	2,4	2850	7,6	4,4	50	29	4 x 2,5	NOT	NOT
FXDL 64-22	3,8	2850	11,6	6,7	76	44	4 x 2,5	NOT	NOT
FBDL 62-22	1,7	2850	5	2,9	26	15	4 x 2,5	NOT	NOT
FBDL 62-21	2,2	2850	6,4	3,7	42	24	4 x 2,5	NOT	NOT
FBDL 64-22	4,5	2850	10	5,8	65	38	4 x 2,5	NOT	NOT
FBDL 66-21	6,6	2850	19,4	12,2	99	57	7 x 2,5	YES	YES

** On standard version.

FDL SERIES (CHANNEL IMPELLER) OPERATING CHARACTERISTICS, 50 Hz

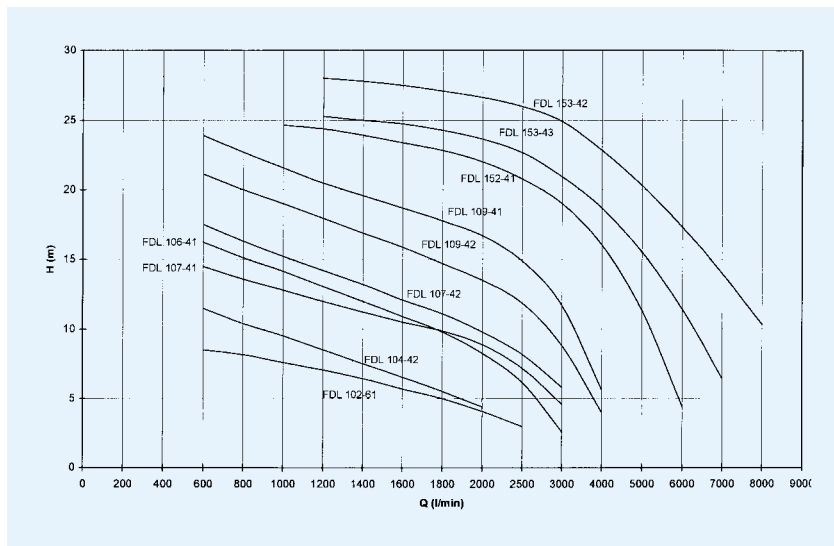
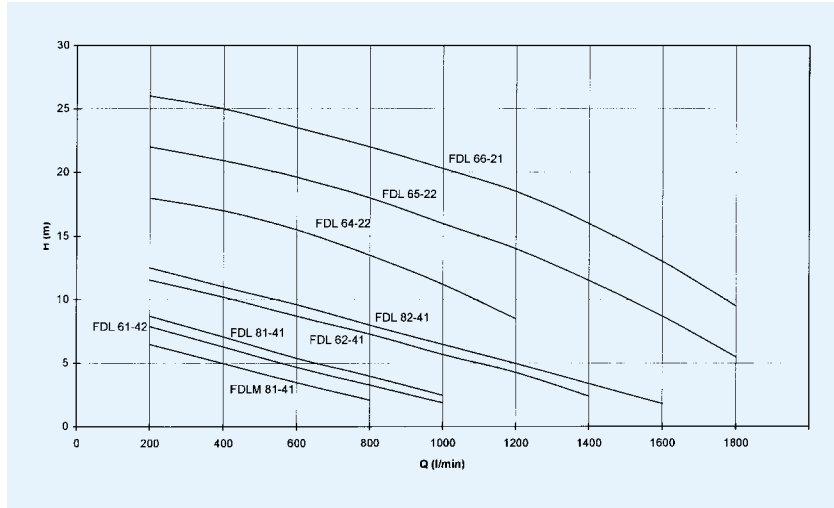

HYDRAULIC PERFORMANCE TABLE, 50 Hz

PUMP TYPE	INPUT POWER kW	rpm	Q = DELIVERY																DNM	SOLIDS HANDLED (mm)	MAX. LIQUID TEMP °C		
			H = TOTAL HEAD METERS COLUMN OF WATER																				
			l/min m ³ /h	200 12	400 24	600 36	800 48	1000 60	1200 72	1400 84	1600 96	1800 108	2000 120	2500 150	3000 180	4000 240	5000 300	6000 360				7000 420	
FDL 61-42	1,7	1450	7,8	6,5	5,3	4	2,6											65	65	40			
FDL 62-41	2,6	1450	11,5	10	8,7	7,4	6,2	4,8	3,3	2								65	65	40			
FDL 64-22	3,5	2850	18	17	15,5	13,5	11,2	8,5										70	30	30			
FDL 65-22	5,2	2850	21,5	20	19	17	16	14	12									70	30	30			
FDL 66-21	6,6	2850	26	25	24	22	20	18	16	13								70	30	30			
FDLM 81-41	1,7	1450	6,5	5	3,5	2,1												80	52	40			
FDL 81-41	2	1450	9	7	5,3	4	2,5											80	52	40			
FDL 82-41	2,8	1450	12	11	9,2	7,5	6,5	5	3,7	2,5								80	76	40			
FDL 102-61	3	950	8,8	8,6	8,2	7,5	7,2	6,9	6,5	5,6	5,2	4,6	3					100	80	40			
FDL 104-42	4,3	1450	14	13	11,5	10,2	9	8	7	6,2	5	4,1						100	-	-			
FDL 106-41	5,7	1450	19	17	16	15	14	13	12	11	10	8	6	3				100	78	40			
FDL 107-41	5,9	1450		15	14,3	13,6	13	12,6	11,5	10,8	9,9	9,2	7,2	5				100	100	40			
FDL 107-42	6,5	1450		18	17	16	15	14	13	12	10	8	5					100	60	40			
FDL 109-42	9,6	1450						20	18,5	17	16	15,4	14,2	13,7	12	9		100	90	40			
FDL 109-41	11,2	1450						23	21,5	20	19	17	16,5	16	14	12	7	100	90	40			
FDL 152-41	15,5	1450						21,5	20,5	20	18,8	18	17	16,5	15	13,5	10	6	150	100	40		
FDL 153-43	23,5	1450						25,8	25,5	25,1	24,6	24	23,8	23,5	22,5	21,5	19,4	17	14	11	150	100	40
FDL 153-42	30,6	1450						28,5	28,2	28	27,8	27,6	27,5	27	26	25	23	20,5	17,5	14	150	100	25

These performances are valid for liquids with density $\rho = 1.0 \text{ kg/dm}^3$ and kinematic viscosity $\gamma = 1 \text{ mm}^2/\text{sec}$.

FDLV SERIES (VORTEX IMPELLER) OPERATING CHARACTERISTICS, 50 Hz

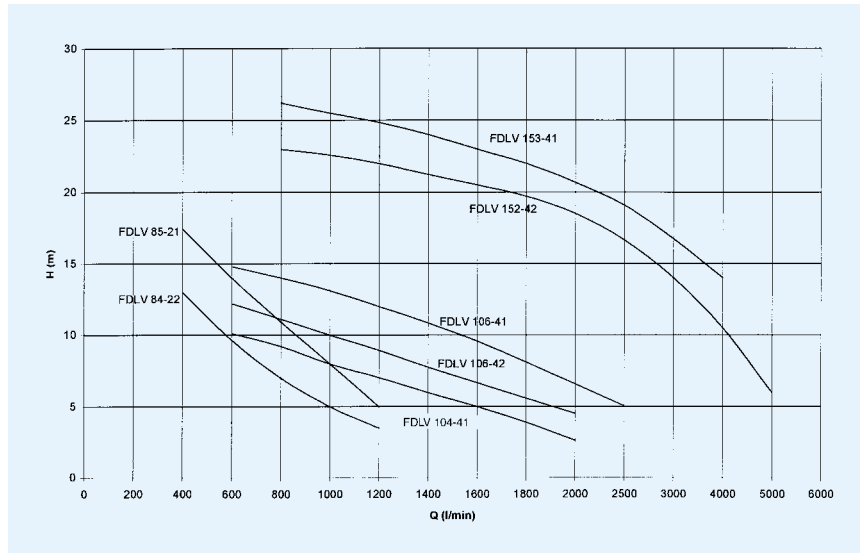
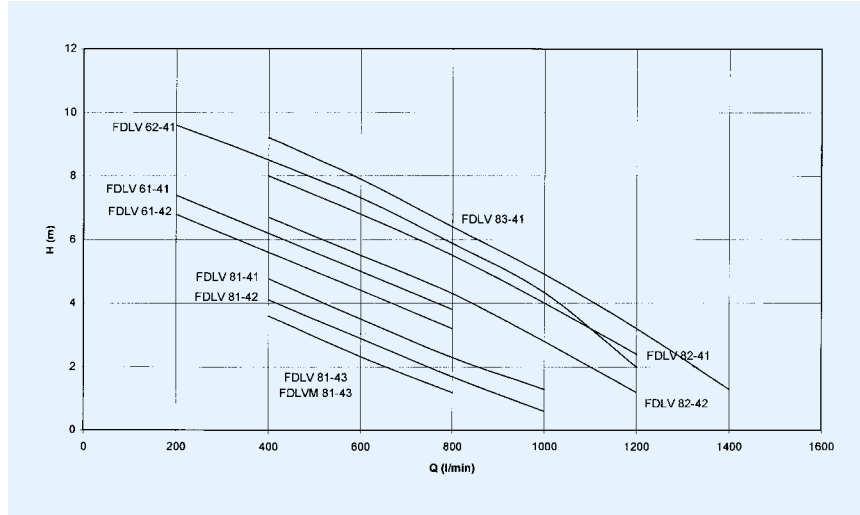

HYDRAULIC PERFORMANCE TABLE, 50 Hz

PUMP TYPE	INPUT POWER kW	rpm	Q = DELIVERY																DNM	SOLIDS HANDLED (mm)	MAX. LIQUID TEMP. °C	
			200	400	600	800	1000	1200	1400	1600	1800	2000	2500	3000	4000	5000						
			m³/h	12	24	36	48	60	72	84	96	108	120	150	180	240	300					
FDLV 61-42	1,5	1450	6,8	5,8	4,4	2,5														65	50	40
FDLV 61-41	1,6	1450	7,4	6,4	5	3,2														65	50	40
FDLV 62-41	2,5	1450	8,6	7,8	6,6	5	3,8	2,3												65	50	40
FDLVM 81-43	1,6	1465	4,8	3,6	2,4	1,2														80	50x60	40
FDLV 81-43	1,5	1450	4,5	3,4	2,2	1,2														80	50x60	40
FDLV 81-42	1,6	1450	5,1	4,1	3	1,7	0,6													80	50x60	40
FDLV 81-41	1,9	1450	5,9	4,8	3,5	2,3	1,3													80	50x60	40
FDLV 82-42	2,4	1400	7,6	6,7	5,5	4,3	2,8	1,2												80	60x50	40
FDLV 82-41	2,8	1400	9	8	6,8	5,2	4	2,4												80	60x50	40
FDLV 83-41	3,2	1400	10,6	9,2	7,9	6,2	5	3,2	1,3											80	50	40
FDLV 84-22	4,5	2860	16	13	10	7	5	3,5												80	50	40
FDLV 85-21	6	2860	22	18	14	11	8	5												80	50	40
FDLV 104-41	4,3	1450		11	9,6	8,5	8,1	7	6	5	3,8									100	70x90	40
FDLV 106-42	5,4	1450		13	12,2	11	10,5	9,2	8,5	7,2	6,2	5								100	70x90	40
FDLV 106-41	6,8	1450		15,2	14,8	13,5	12,8	12	10,5	9,2	8,2	7	3,5							100	70x90	40
FDLV 152-42	24,7	1460				23	22,8	22	20,5	20	19,5	18,5	16	14	10,5	6				150	100	25
FDLV 153-41	30	1460				26,2	25,5	24,5	23	22,5	22	21	18,2	17	13					150	100	25

These performances are valid for liquids with density $\rho = 1.0 \text{ kg/dm}^3$ and kinematic viscosity $\gamma = 1 \text{ mm}^2/\text{sec}$.

FXDL (V) SERIES OPERATING CHARACTERISTICS, 50 Hz

FXDL (V)

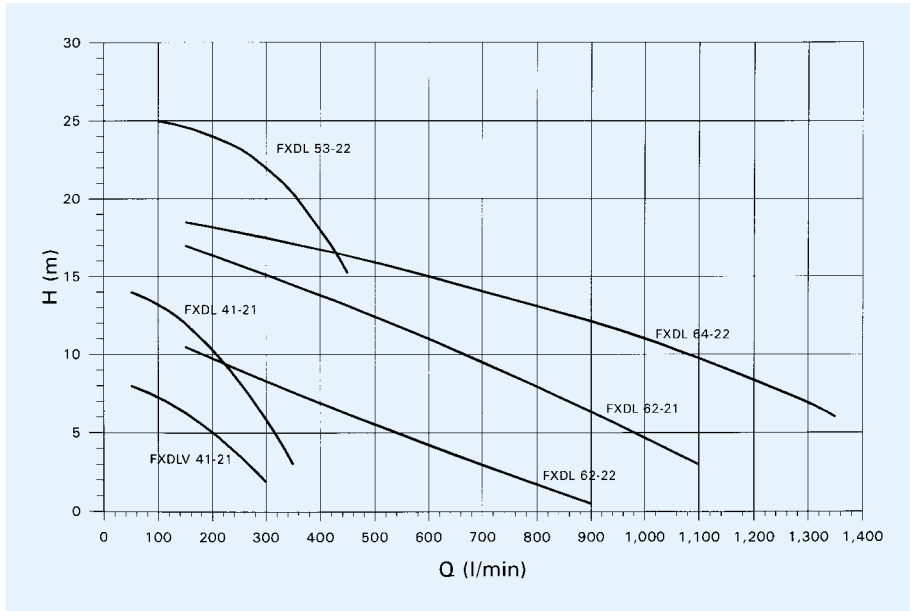

FBDL

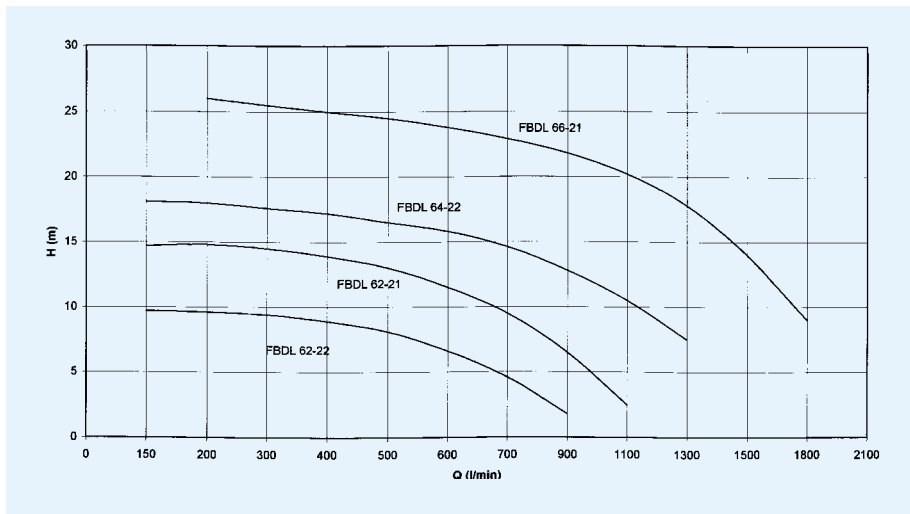

HYDRAULIC PERFORMANCE TABLE, 50 Hz

PUMP TYPE	INPUT POWER kW	rpm	Q = DELIVERY																DNM	SOLIDS HANDLED (mm)	TEMP. MAX. LIQUIDO °C															
			l/min 50		100		150		200		300		400		500		600					700		900		1100		1300		1500		1800				
			m ³ /h	3	6	9	12	18	24	30	36	42	54	66	78	90	108																			
FXDLV 41-21	0,8	2850	8	7,5	6,3	5	1,8																										1"½	30	40	
FXDL 41-21	1	2850	14,8	13,5	12	10	5,5																											1"½	6	40
FXDL 53-22	3,2	2860		25,2	24,8	23,8	22	18																										2"	6	25
FXDL 62-22	1,7	2850		11,1	10,5	9,5	8,6	7,5	6,2	5	3,5																							70	30	40
FXDL 62-21	2,4	2860			17	16,5	15,1	13,5	12,5	11	9	6,5	3																					70	30	40
FXDL 64-22	3,8	2860			18,5	18	17,4	17	16	15	14	12	9,5	6,9																				70	30	25
FBDL 62-22	1,7	2850			11	10,1	9	7,5	6,8	5,5	4,6	1,8																						70	30	40
FBDL 62-21	2,2	2850			16,5	15,9	14,5	13	11,5	10,5	9	5,9	2,5																					70	30	40
FBDL 64-22	3,5	2850			18,1	18	17,6	17	16,2	15,5	14,8	12,5	10	7,5																				70	30	30
FBDL 66-21	6,6	2850				26	25,5	26	24,5	24	23	21	19	17,5	14	9																		70	30	30

These performances are valid for liquids with density $\rho = 1.0 \text{ kg/dm}^3$ and kinematic viscosity $\gamma = 1 \text{ mm}^2/\text{sec}$.

FDL (V) - FXDL (V) - FBDL SERIES DIMENSIONS AND WEIGHTS

INSTALLATION WITH DUAL GUIDE PIPE LOWERING SYSTEM

PUMP TYPE	A	B	C	D	F	G	H	I	J	K	L	M	DN	kg
FDL 64 - 22	95	464	85	410	370	256	494	62	250	190	143	160	70	50
FDL 66 - 21 et FDL 65 - 22	95	464	85	410	370	256	570	62	250	190	143	160	70	70
FDL 81 - 41	95	657	85	416	370	256	565	85	250	250	156	160	80	67
FDL 82 - 41	95	657	85	416	370	256	590	85	250	250	156	160	80	71
FDL 102 - 61	105	761	85	466	400	266	620	80	250	300	210	160	100	118
FDL 106 - 41	105	761	85	466	400	266	620	80	250	300	210	160	100	116
FDL 107 - 41	105	711	85	436	400	266	730	50	250	270	190	160	100	125
FDL 107 - 42	105	761	85	466	400	266	715	80	250	300	210	160	100	134
FDL 109 - 41 et 42	105	720	85	440	400	266	826	80	250	280	195	160	100	138
FDL 152 - 41	138	931	85	566	252	373	825	90	300	400	280	200	150	280
FDL 153 - 43	138	931	85	566	525	373	955	90	300	400	280	200	150	328
FDL 153 - 42	138	931	85	466	525	373	955	90	300	400	280	200	150	328
FDLV 61 - 41 et FDLV 62 - 41	65	528	85	299	385	300	510	140	180	225	145	205	65	50
FDLV 61 - 42 et FDLV 62 - 41	65	528	85	299	385	300	510	140	180	225	145	205	65	50
FDLM 81 - 41	95	657	85	416	370	256	565	85	250	250	156	160	80	67
FDLV 81 - 43	95	646	85	411	370	256	510	122	250	245	150	160	80	57
FDLV 81 - 42	95	646	85	411	370	256	510	122	250	245	150	160	80	57
FDLV 81 - 41	95	646	85	411	370	256	510	122	250	245	150	160	80	57
FDLV 82 - 42	95	646	85	411	370	256	545	122	250	245	150	160	80	61
FDLV 82 - 41	95	646	85	411	370	256	545	122	250	245	150	160	80	61
FDLV 83 - 41	95	646	85	411	370	256	545	122	250	245	150	160	80	62
FDLV 84 - 22	95	649	85	414	370	256	621	60	250	248	150	160	80	70
FDLV 85 - 21	95	649	85	414	370	256	621	60	250	248	150	160	80	70
FDLV 104 - 41	105	711	85	446	400	266	642	90	250	280	180	160	100	115
FDLV 106 - 41	105	711	85	446	400	266	720	90	250	280	180	160	100	120
FDLV 152 - 42	138	965	85	616	525	373	1014	125	300	450	264	200	150	330
FDLV 153 - 41	138	965	85	616	525	373	1014	125	300	450	264	200	150	330
FDLV M 81 - 43	95	646	85	411	370	256	510	122	250	245	150	160	80	57
FXDLV 41 - 21							422			135	105		1 1/2"	30
FXDL 41 - 21							422			135	105		1 1/2"	30
FXDL 53 - 22							440			205	140		2"	45
FXDL 62 - 22							440			143	121		70	40
FXDL 62 - 21							494			190	143		70	51
FXDL 64 - 21							494			190	143		70	51
FBDL 62 - 22							440			143	121		70	39
FBDL 62 - 21							494			191	143		70	52
FBDL 64 - 22							494			190	143		70	52
FBDL 66 - 21							570			190	143		70	70

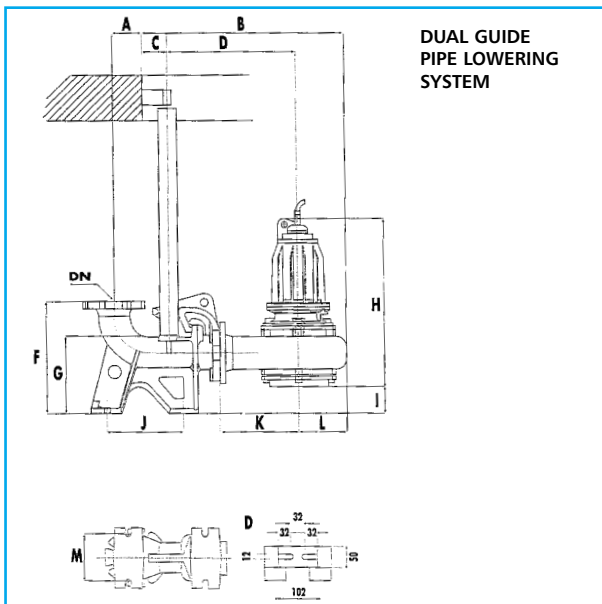

A slide and DN 70-80-100-150 seal is available on request for coupling of FDL and FDLV series to lowering systems with one guide pipe.
NOTE: the pump drawing is purely indicative. For more information please contact our sales network.