

P-PAB-PSA SERIES

PERIPHERAL PUMPS

Peripheral pumps can develop high heads using lower-powered motors. The P-PAB-PSA series is the result of Lowara's thirty-year experience in the manufacture of these products.

APPLICATIONS

- **Clear water handling for domestic use.**
- Lawn sprinkling.
- Assembled with pressure vessels for pressure boosting in various applications.
- Washing.
- **Boiler feed (the PSA series is specially indicated).**
- Use in hot water systems (PAB and PABLB models)

SPECIFICATIONS

- P-PAB series with front suction and radial delivery. PSA-PABLB series with radial suction and delivery.
- **Capacity:** up to **62 l/min (3,72 m³/h)**.
- **Head:** up to **82 m (8,2 bar)**.
- **Maximum operating pressure: 8 bar (10 bar for PSA series).**
- **Continuous duty.**
- **Temperature of pumped liquid: -10°C to +40°C for P series, 80°C for PSA and PAB, PABLB series.**
- **Max ambient temperature: 40°C.**
- Enclosed motor with internal ventilation through casing for series P, (P16, P21, P30, P40) pumps, enclosed with external ventilation and aluminium alloy casing for (P60, P70), PSA and PAB, PABLB series pumps.
- Versions:
 - Single-phase** 220 V 50 Hz, permanently connected capacitor and built-in automatic reset overload protection.
 - Three-phase** 220-240/380-415 V 50 Hz, thermal overload protection to be provided by user.
- **Power** up to **1,1 kW**.
- Class **F Insulation**.
- **IP44 protection for models P16, P21, P30, P40, PAB, PABLB, (IP55 for models P60, P70 and PSA).**

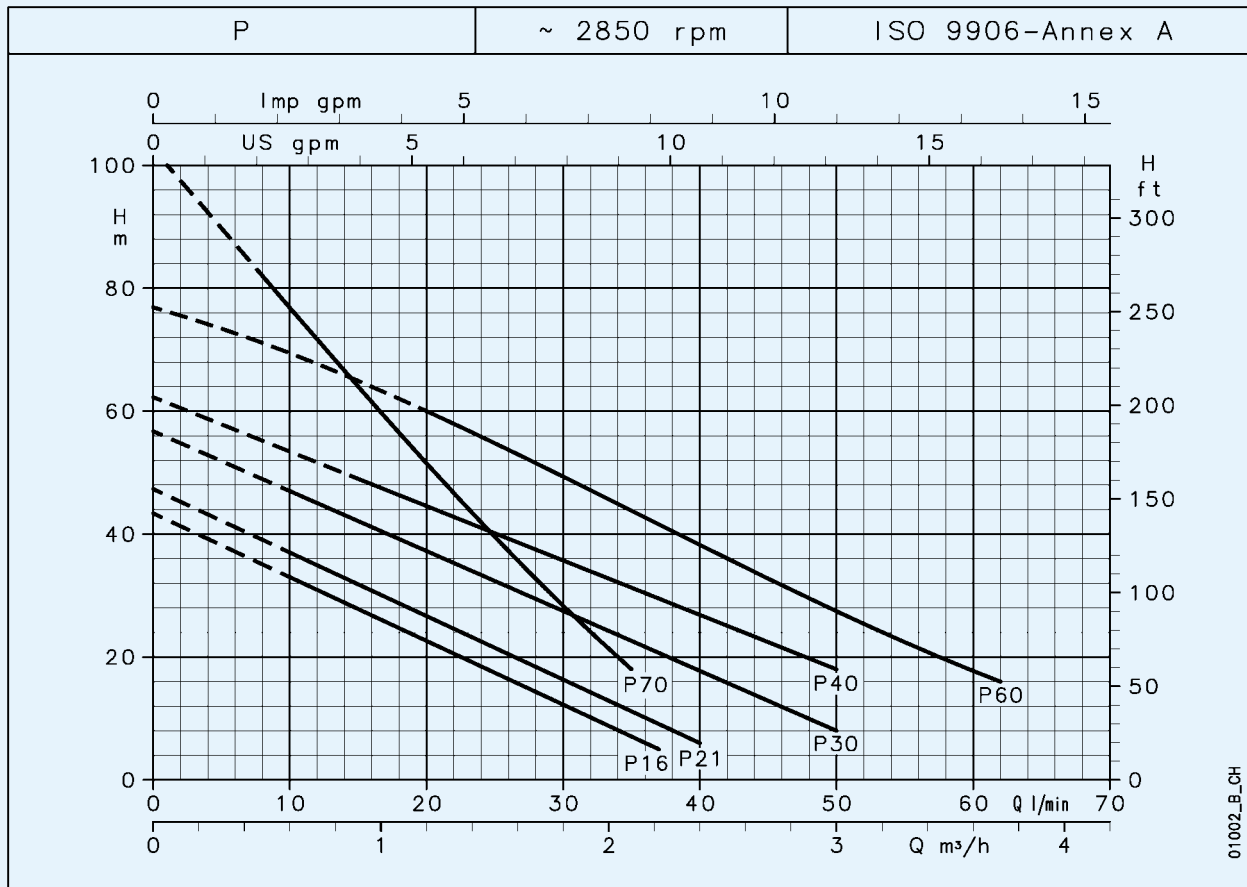

TABLE OF MATERIALS

PART	MATERIAL
Pump body Adapter	CAST IRON * (P, PSA) (PSA HAS BRASS FITTINGS TO PREVENT RUST FROM JAMMING THE IMPELLER) BRONZE (PAB, PABLB)
Impeller	BRASS
Shaft extension (P16, P21, P30, P40)	STAINLESS STEEL (AISI 303 – DIN 1.4305)
Shaft extension (P60, P70, PSA, PAB, PABLB)	STAINLESS STEEL (AISI 416 – DIN 1.4005)
Fill plug	BRASS
Mechanical seal	CARBON/CERAMIC/NBR
O-ring seals	NBR

* P version available in a special option with pump body in bronze.

**P SERIES
 OPERATING CHARACTERISTICS AT 2850 rpm 50 Hz**



PUMP TYPE	RATED POWER		Q = DELIVERY											
			l/min	0	8	10	15	20	35	37	40	50	62	
				m ³ /h	0	0.48	0.60	0.90	1.20	2.10	2.22	2.40	3.00	3.72
H = TOTAL HEAD METERS COLUMN OF WATER														
P(M)16	0.3	0.4	43.4		33.0	27.8	22.6	7.1	5.0					
P(M)21	0.37	0.5	47.4		37.0	31.8	26.7	11.2	9.1	6.0				
P(M)30	0.5	0.7	56.8		47.0	42.1	37.3	22.6	20.7	17.8	8.0			
P(M)40	0.6	0.8	62.3			49.0	44.6	31.3	29.5	26.9	18.0			
P(M)60	1.1	1.5	76.9				60.0	43.8	41.6	38.2	27.5	16.0		
P(M)70	0.75	1	102.6	82.0	76.8	64.0	51.5	18.0						

These performances are valid for liquids with density $\rho = 1.0 \text{ kg/dm}^3$ and kinematic viscosity $\gamma = 1 \text{ mm}^2/\text{sec}$.

p-2p50_a_th

PUMP TYPE	INPUT POWER*	INPUT CURRENT*	CAPACITOR
SINGLE-PHASE	kW	A	$\mu\text{F} / 450 \text{ V}$
PM16	0.5	2.4	10
PM21	0.58	2.8	12.5
PM30	0.8	4	16
PM40	1.15	5.3	20
PM60	1.77	7.95	30
PM70	1.36	6.12	25

PUMP TYPE	INPUT POWER*	INPUT CURRENT*	INPUT CURRENT*
THREE-PHASE	kW	A	A
P16	0.48	1.55	0.9
P21	0.55	1.9	1.1
P30	0.78	2.8	1.6
P40	1.1	3.6	2.1
P60	1.72	5.23	3.02
P70	1.3	4.36	2.52

* Maximum value in specified range

p-2p50_a_th

**PAB SERIES
 OPERATING CHARACTERISTICS AT 2850 rpm 50 Hz**

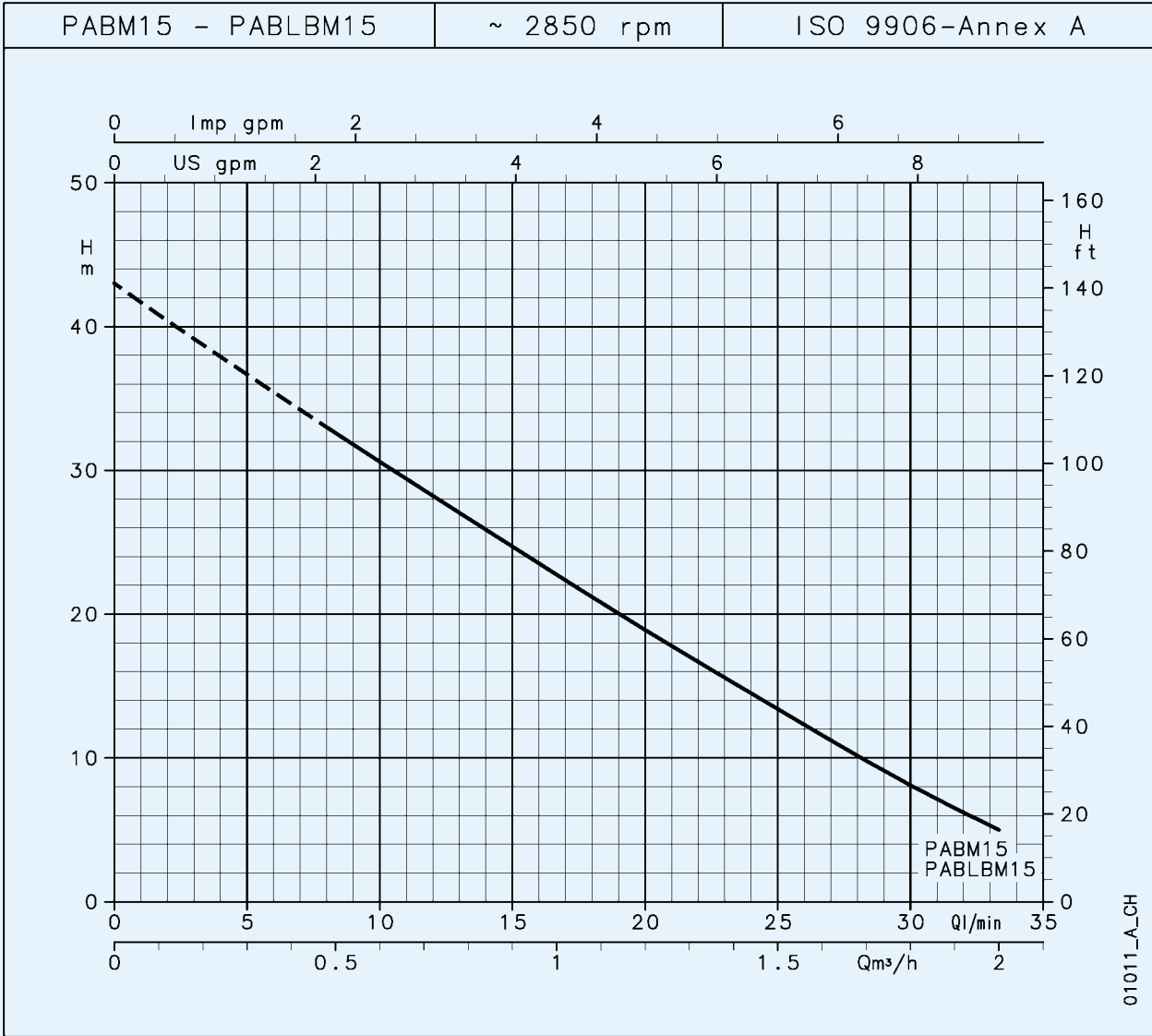

PUMP TYPE	RATED POWER		Q = DELIVERY								
			l/min	0	8	10	15	20	25	30	33
			m ³ /h	0	0.48	0.60	0.90	1.20	1.50	1.80	1.98
			H = TOTAL HEAD METERS COLUMN OF WATER								
PABM15	0.37	0.5	43.0	33.0	30.6	24.7	18.9	13.4	8.1	5.0	
PABLBM15	0.37	0.5	43.0	33.0	30.6	24.7	18.9	13.4	8.1	5.0	

These performances are valid for liquids with density $\rho = 1.0 \text{ kg/dm}^3$ and kinematic viscosity $\gamma = 1 \text{ mm}^2/\text{sec}$.

pab-2p50_a_th

PUMP TYPE	INPUT POWER*	INPUT CURRENT*	CAPACITOR
SINGLE-PHASE		220-240 V	
	kW	A	$\mu\text{F} / 450 \text{ V}$
PABM15	0.47	2.1	10
PABLBM15	0.47	2.1	10

PUMP TYPE	INPUT POWER*	INPUT CURRENT*	INPUT CURRENT*
THREE-PHASE		220-240 V	380-415 V
	kW	A	A
-	-	-	-
-	-	-	-

* Maximum value in specified range

pab-2p50_a_th

**PSA70 SERIES
 OPERATING CHARACTERISTICS AT 2850 rpm 50 Hz**

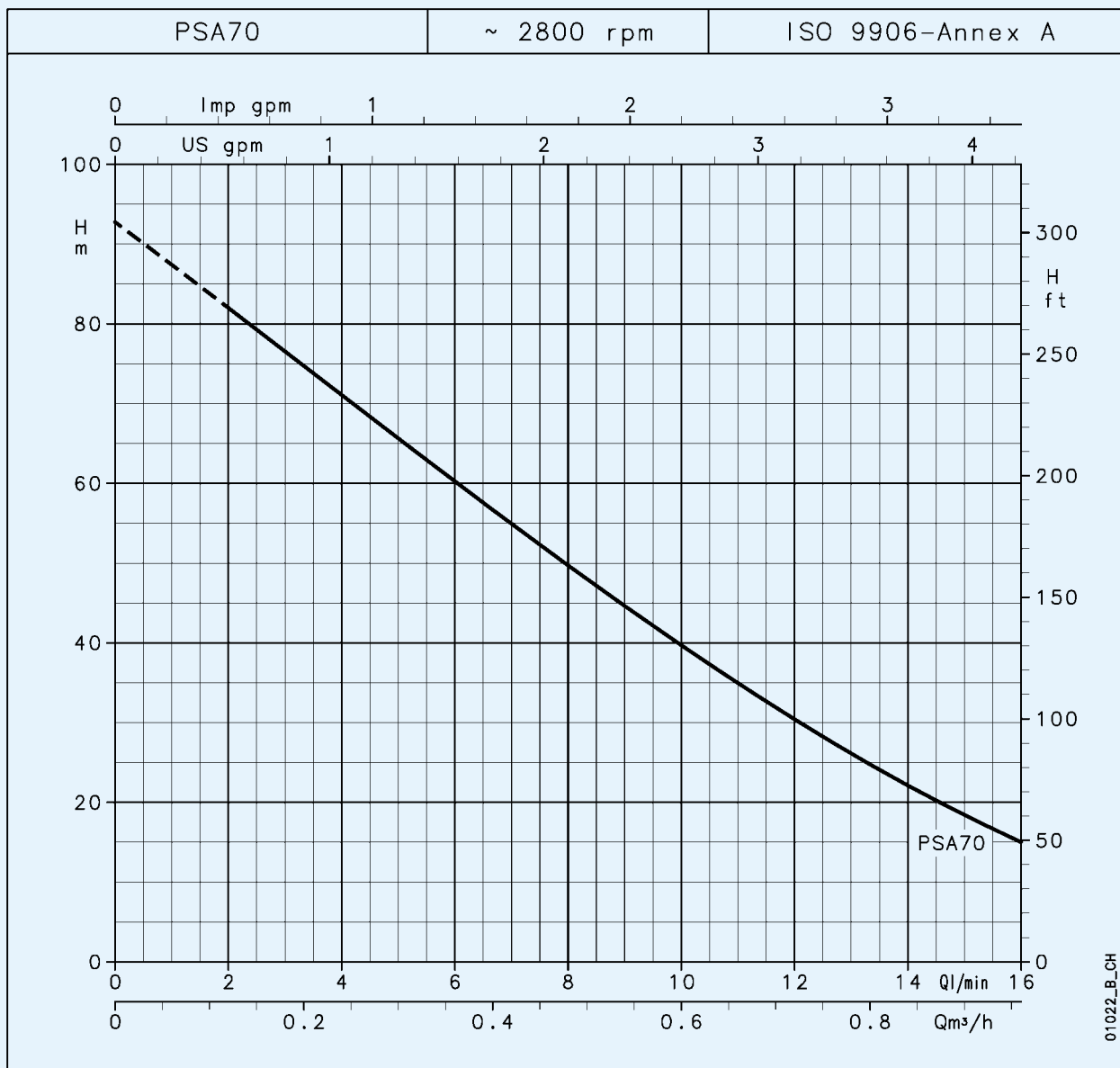

PUMP TYPE	RATED POWER		Q = DELIVERY							
			l/min	2	4	8	10	12	14	16
			0	0.12	0.24	0.48	0.6	0.72	0.84	0.96
			m³/h							
			H = TOTAL HEAD METERS COLUMN OF WATER							
PSA(M)70	0.37	0.5	92.8	82.0	71.1	49.7	39.7	30.4	22.1	15.0

These performances are valid for liquids with density $\rho = 1.0 \text{ kg/dm}^3$ and kinematic viscosity $\gamma = 1 \text{ mm}^2/\text{sec}$.

psa-2p50_a_th

PUMP TYPE	INPUT POWER*	INPUT CURRENT*	CAPACITOR
SINGLE-PHASE		220-240 V	
	kW	A	$\mu\text{F} / 450 \text{ V}$
PSAM70	0.75	3.41	16

PUMP TYPE	INPUT POWER*	INPUT CURRENT*	INPUT CURRENT*
THREE-PHASE		220-240 V	380-415 V
	kW	A	A
PSA70	0.76	2.75	1.59

* Maximum value in specified range

psa-2p50_a_te

DIMENSIONS AND WEIGHTS, P SERIES

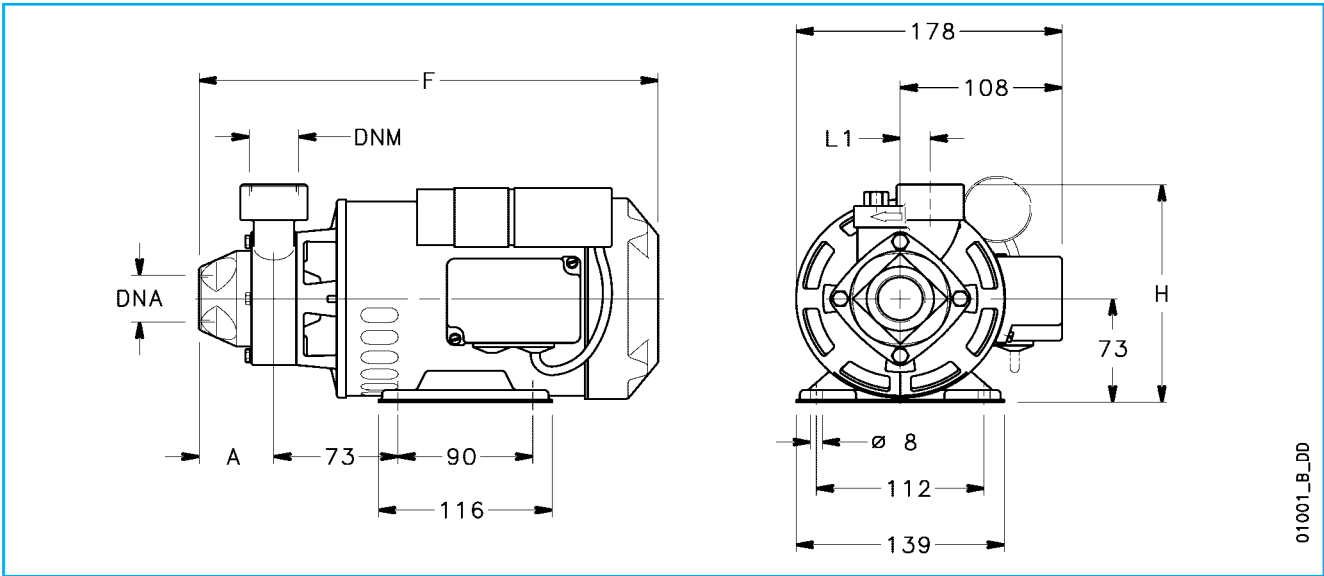

01001_B_DD

PUMP TYPE	DIMENSIONS (mm)				DNA	DNM	WEIGHT kg
	A	F	H	L1			
P16-PM16	50	280	153	18.5	Rp 1	Rp 1	8.5
P21-PM21	50	280	153	18.5	Rp 1	Rp 1	9.5
P30-PM30	55	285	163	20	Rp 1	Rp 1	11
P40-PM40	54.5	305	163	20	Rp 1	Rp 1	11.5

p-2p50_a_td

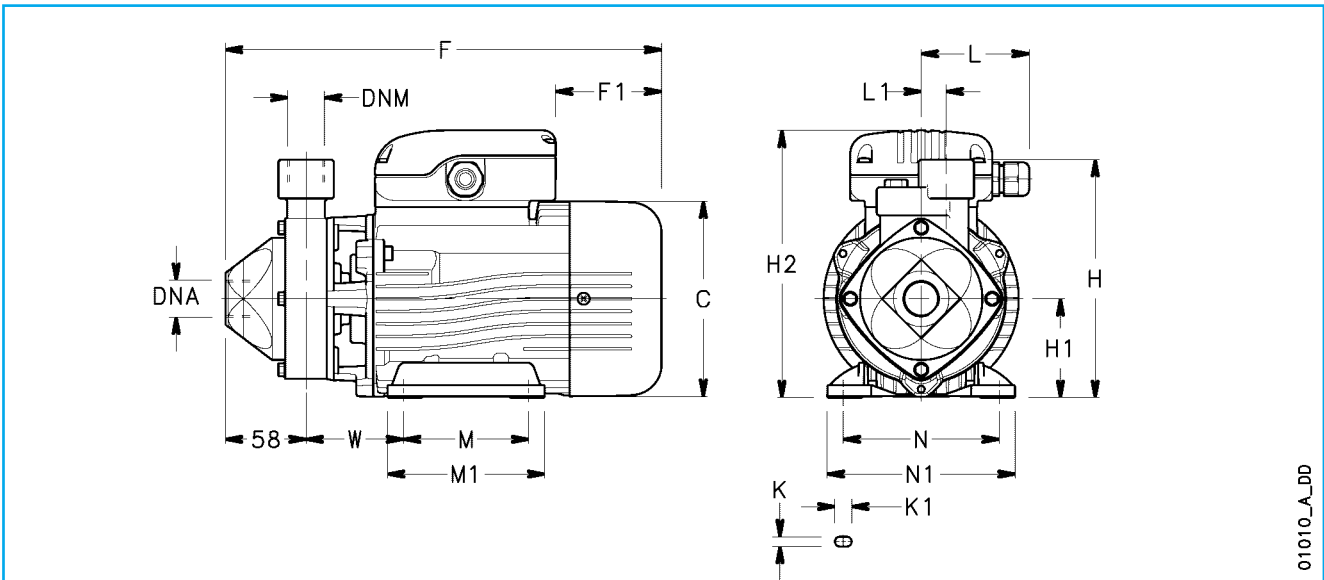

01010_A_DD

PUMP TYPE	DIMENSIONS (mm)															DNA	DNM	WEIGHT kg
	C	F	F1	H	H1	H2	L	L1	M	M1	N	N1	K	K1	W			
P60	155	354	113	180	80	209	78	20	100	124	125	153	9	12	83	Rp 1	Rp 1	8.5
PM60	155	354	68	180	80	217	81	20	100	124	125	153	9	12	83	Rp 1	Rp 1	9.5
P70-PM70	140	314	76	171	71	192	78	18	90	113	112	135	7	12	70	Rp ¾	Rp ¾	11

p60-70-2p50_a_td

DIMENSIONS AND WEIGHTS, PAB AND PSA70 SERIES

